



HRE-0130-1 HEAT REACTIVATED DESICCANT AIR DRYER GENERAL ARRANGEMENT

TOLERANCES UNLESS
OTHERWISE SPECIFIED:

- FRACTIONS = ± 1/4 "
- ANGLES = ± 3°
- INCHES = ± 1/2 "
- FINISH = 250

THE SPECIFICATIONS AND DRAWINGS DISCLOSED HEREIN ARE THE SOLE PROPERTY OF ALTEC AIR, AND SHALL NOT BE COPIED OR USED AS THE BASIS FOR SALE OR MANUFACTURE WITHOUT EXPRESS WRITTEN PERMISSION.

REVISION LOG

REV.	ECO.	DESCRIPTION	DATE	APPROVED
A				

DRAWING NO. **AT20-946** REV. **A**

DRAWN: WS DATE: 8/24/2017
 CHECKED: DATE: SCALE: N/A SHEET: 1 OF 2

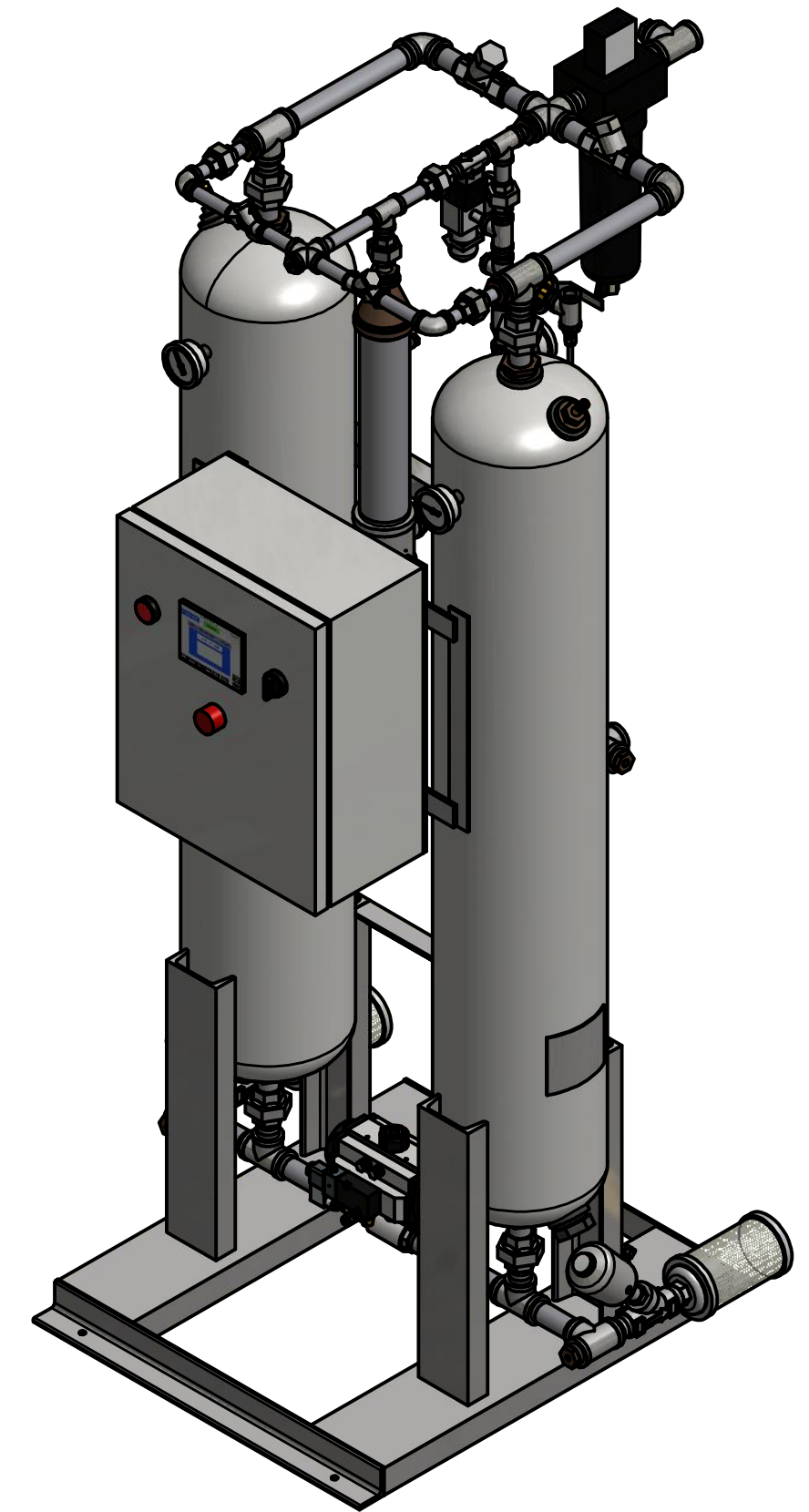
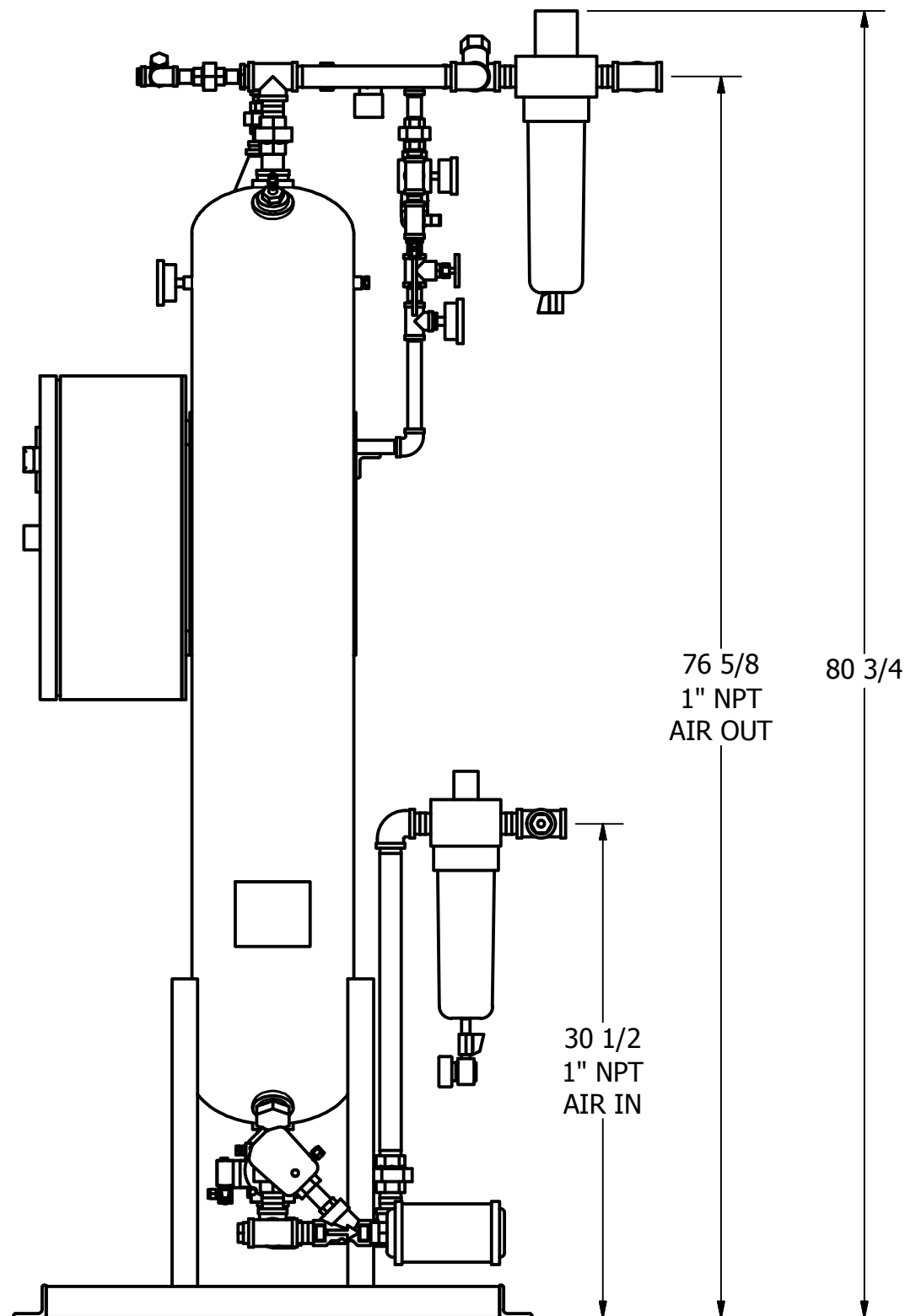
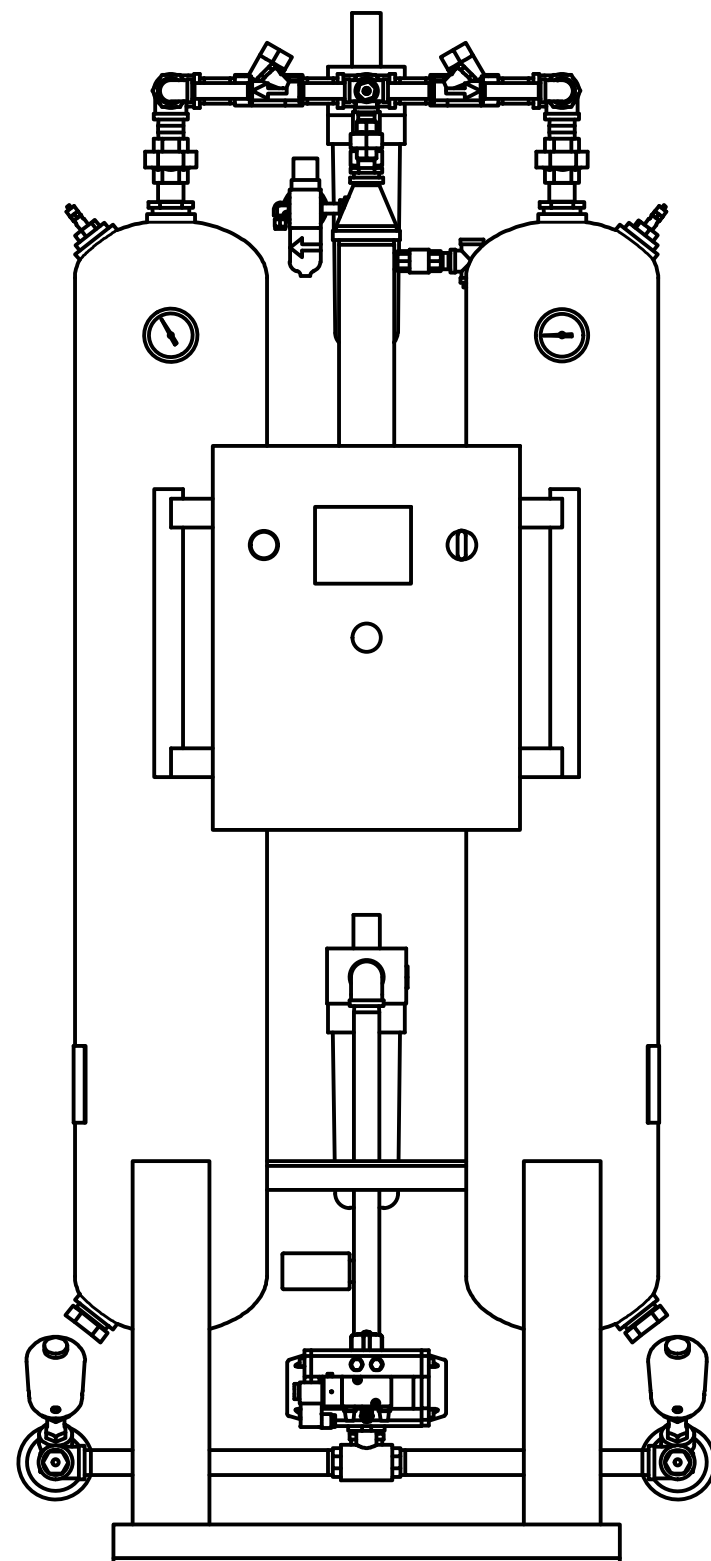
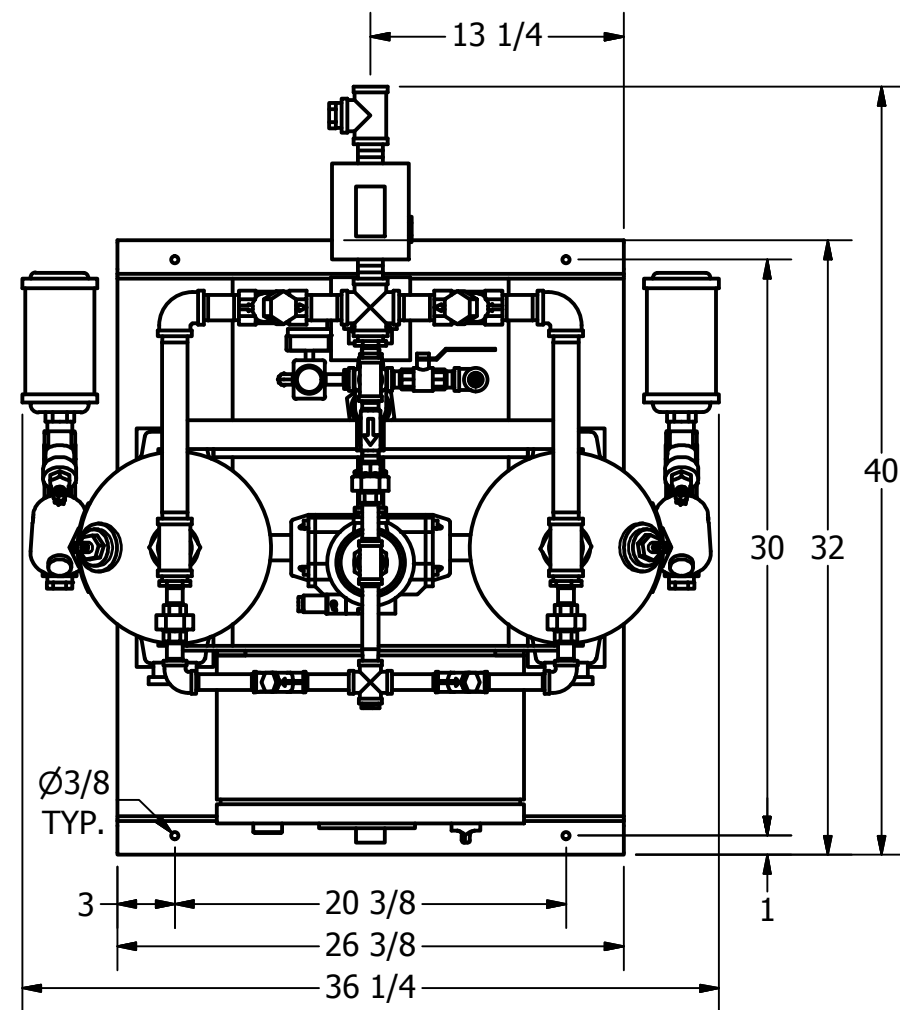

PRELIMINARY



HRE-0130-1 HEAT REACTIVATED DESICCANT AIR DRYER GENERAL ARRANGEMENT

TOLERANCES UNLESS OTHERWISE SPECIFIED:

- FRACTIONS = ± 1/4 "
- ANGLES = ± 3°
- INCHES = ± 1/2 "
- FINISH = 250

THE SPECIFICATIONS AND DRAWINGS DISCLOSED HEREIN ARE THE SOLE PROPERTY OF ALTEC AIR, AND SHALL NOT BE COPIED OR USED AS THE BASIS FOR SALE OR MANUFACTURE WITHOUT EXPRESS WRITTEN PERMISSION.

REVISION LOG

REV.	ECO.	DESCRIPTION	DATE	APPROVED
A				

DRAWING NO. **AT20-946** REV. **A**

DRAWN: WS DATE: 8/24/2017
CHECKED: DATE:

SCALE: N/A SHEET: 2 OF 2

PARTS LIST

ITEM	QTY	DESCRIPTION
1	2	CHECK VALVE, PURGE
2	1	SOLENOID, REPRESS
3	2	CHECK VALVE, OUTLET
4	1	PARTICULATE AFTER-FILTER
5	1	MOISTURE INDICATOR
6	1	GATE VALVE, PURGE
7	1	PRESSURE GAUGE, PURGE
8	1	PRESSURE REGULATOR, CONTROL
9	1	PRESSURE GAUGE, CONTROL
10	1	DEW POINT MONITOR (OPTIONAL)
11	2	RELIEF VALVE, TANK
12	2	PRESSURE GAUGE, CONTROL
13	1	1.5 KW HEATER
14	1	3-WAY BALL VALVE, INLET
15	1	COALESCER PRE-FILTER
16	1	TIMER DRAIN
17	2	ANGLE BODY VALVE, EXHAUST
18	2	MUFFLER, EXHAUST
19	200 LBS	DESICCANT

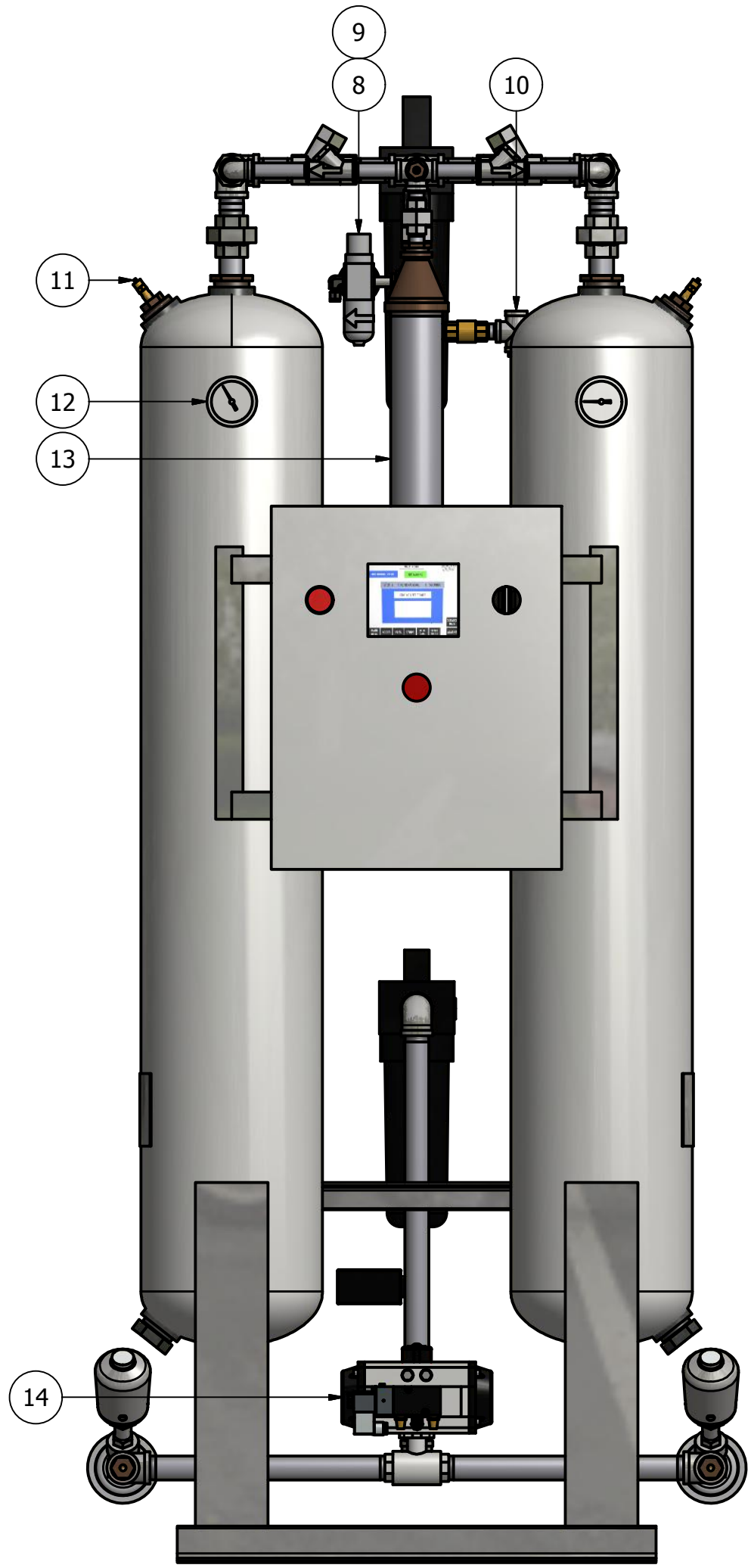
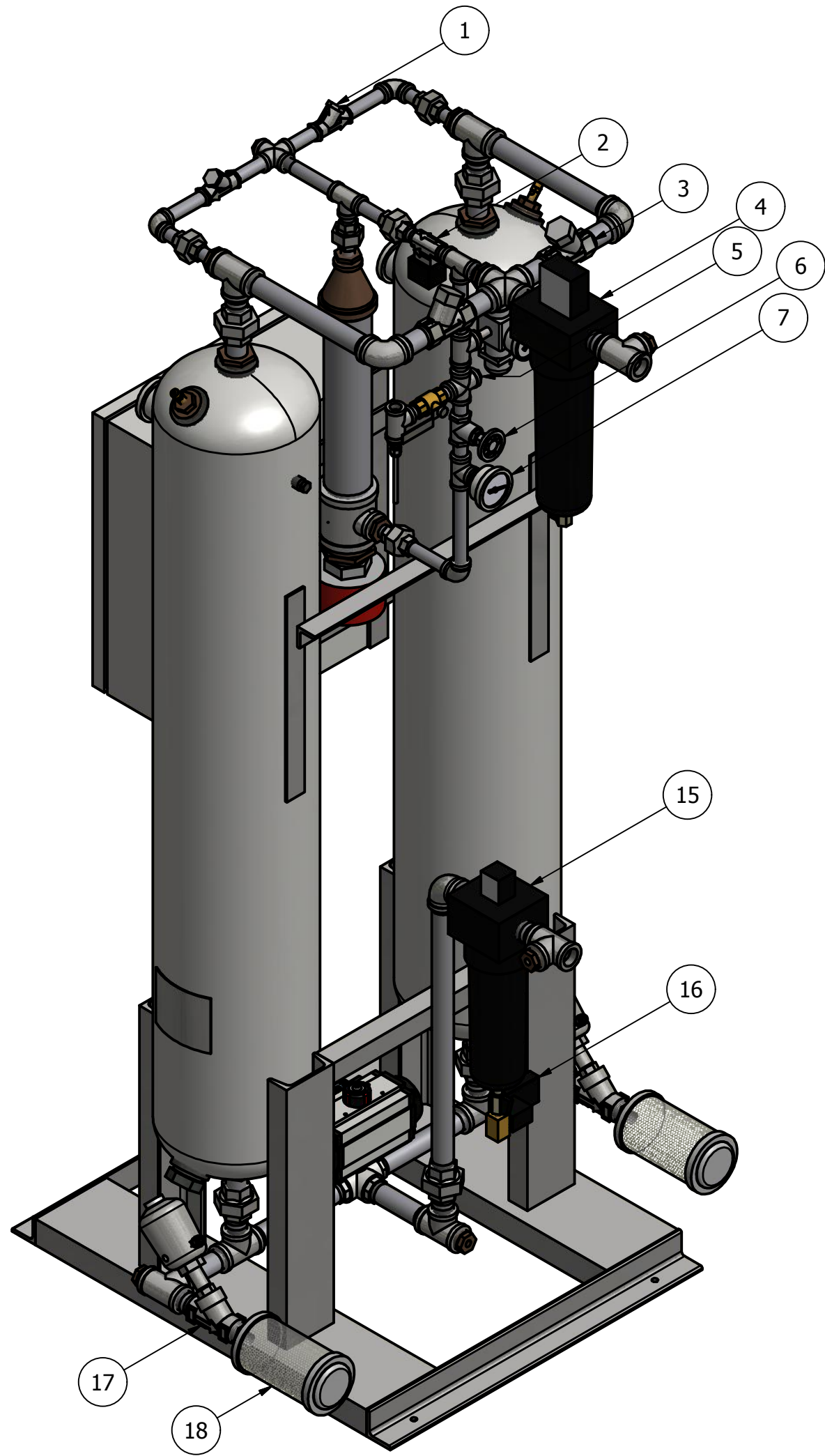

PRELIMINARY